

SL7003

Shoulder Press

OWNER'S MANUAL

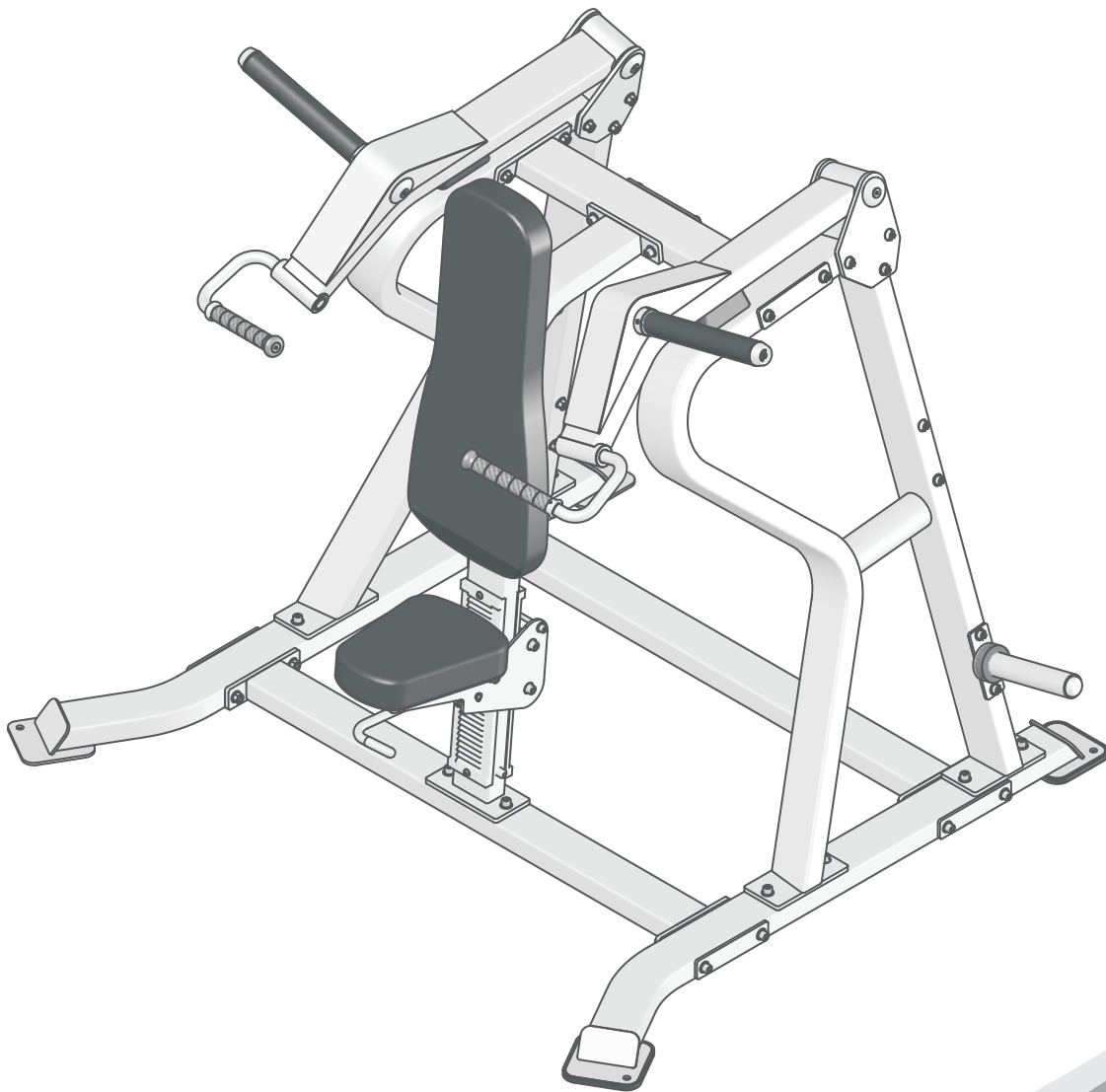

! CAUTION

Read all precautions
and instructions in this manual
before using this equipment

! CAUTION

Read all precautions and instructions in this manual before using this equipment.

Table Of Contents

Important Safety Instructions-----	3
Instructions-----	4
Parts List-----	5
Exploded View -----	6
Measurement Guide-----	7
Assembly Instructions-----	8
Assembly-----	9
Maintenance Schedule-----	14
General Maintenance Information-----	15
Weight Training Tips-----	16
Specifications-----	16

Important Safety Instructions

Before beginning any fitness program, you should obtain a complete physical examination from your physician. When using exercise equipment, basic precautions should always be taken, including the following:

- * Read all instructions before using the equipment. These instructions are written to ensure your safety and to protect the unit.
- * Do not allow children on or near the equipment.
- * Use the equipment only for its intended purpose as described in this guide. Do not use accessory attachments that are not recommended by the manufacturer: such attachments might cause injuries.
- * Wear proper exercise clothing and shoes for your workout----no loose clothing.
- * Be careful when getting on or off the equipment.
- * Do not overexert yourself or work to exhaustion.
- * If you feel any pain or abnormal symptoms, stop your workout immediately and consult your physician.
- * Never operate the unit when it has been dropped or damaged.
- * Never drop or insert anything into any opening in the equipment.
- * Always check the unit and its cables before each use. Make sure that all fasteners and cables are secure and in good working condition.
- * Frayed or worn cables can be dangerous and may cause injury. Periodically check these cables for any indication of wear.
- * Keep hands, limbs, loose clothing and long hair well out of the way of moving parts.
- * Do not attempt to lift more weight than you can control safely.
- * Do not use the equipment outdoors.

Personal Safety During Assembly

- * Read each step in the assembly instructions and follow the steps in sequence. Do not skip ahead. If you skip ahead, you may learn later that you have to disassemble components and that you may have damaged the equipment.
- * Assemble and operate the equipment on a solid, level surface. Locate the unit a few feet from walls or furniture to provide easy access. The equipment is designed for your enjoyment. By following these precautions and using common sense, you will have many safe and pleasurable hours of healthful exercise with the equipment.

Instructions

Before beginning assembly please take the time to read instructions thoroughly. Please use the various lists in this manual to make sure that all parts have been included in your shipment. When ordering, use part number and description from the lists. Use only our replacement part when servicing. Failure to do so will void your warranty and could result in personal injury.

The equipment is designed to provide the smoothest, most effective exercise motion possible. After assembly, you should check all functions to ensure correct operation. If you experience problems, first recheck the assembly instructions to locate any possible errors made during assembly. If you are unable to correct the problem, call your authorized dealer. Be sure to have your serial number and this manual when calling. When all parts have been accounted for, continue on.

Tools Required

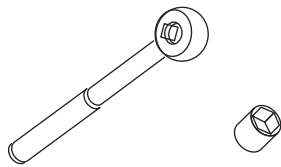

Ratchet Wrench and Socket

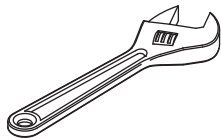

Adjustable Wrench

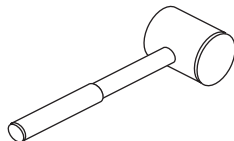

Rubber Mallet

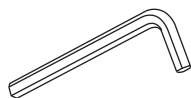

Hex Key Wrench Set

Parts List

NOTE: SOME OF THESE PARTS MAY COME PRE-INSTALLED

Item No.	Description	Qty	No parts	Item No.	Description	Qty	No parts
1	left Upright Frame	1	SL70030100	36	Plastic Sleeve	2	SL70013200
2	Up Cross Frame	1	SL70030200	37	Seat Pad	1	SL70013000V1
3	Right Upright Frame	1	SL70030300	38	Large Rubber Bumper	2	PL380800
4	Back Standing Frame	1	SL70030400	39	Aluminium Cap Φ 25	2	IT90102100
5	Adjustable Handle	1	SL70012800	40	Aluminium Ring Φ 25	2	IT90102200
6	Right Arm Frame	1	SL70030600	41	End Plug	4	RF-6012500
7	Seat Frame	1	SL70073800	42	Rubber Grip	1	CG50001700
8	Left Arm Frame	1	SL70030800	43	Rubber Foot	4	CWRVL0051200
9	Front Cross Frame	1	SL70030900	44	Socket Set Screw M8*6	4	GB77M8*6DHS2
10	Left Bottom Frame	1	SL70031000	45	Tapered Roller Bearing	4	
11	Wheel Shaft	3	SL70012500	46	External Retaining Ring Φ 12	2	GB894.112FH12
12	Right Bottom Frame	1	SL70031200	47	Socket Head Cap Screw M12*155	6	GB70M12*155DHS20
13	Rear Cross Frame	1	SL70031300	48	Socket Head Cap Screw M12*145	3	GB70M12*145DHS20
14	Weight Horn Assembly	2	SL70010900	49	Socket Head Cap Screw M12*135	14	GB70M12*135DHS20
15	Weight Plate Storage	4	SL70100300	50	Socket Head Cap Screw M12*125	8	GB70M12*125DHS20
16	Pivot Shaft Φ 30	2	SL70011500	51	Socket Head Cap Screw M12*90	4	GB70M12*90DHS20
17	Pivot Plate 1	2	SL70011300	52	Socket Head Cap Screw M12*35	12	GB70M12*35*35DHS20NL
18	Pivot Plate 2	2	SL70011400	53	Flat Head Cap Screw M12*30	4	CNLM12*30DS20NL
19	Front Plastic Plate	1	SL70011100	54	Flat Head Cap Screw M12*50	2	CNLM12*50*50DS20NL
20	Rear Plastic Plate	1	SL70011200	55	Flat Head Cap Screw M10*25	2	CNLM10*25DS20NL
21	Rubber Bumper	2	SL70011600	56	Socket Head Cap Screw M10*145	1	GB70M10*145DHS20
22	Weight Horn Rubber Donut	4	HF985A1500	57	Button Head Cap Screw M10*75	1	PNLM10*75DHS2
23	Domed Aluminium Cap	6	SL70011700	58	Button Head Cap Screw M10*30	3	PNLM10*30*30DHS20
24	Long Weight Horn Sleeve	2	SL70011800	59	Button Head Cap Screw M8*70	2	
25	Weight Horn Sleeve	4	SL70100400	60	Socket Set Screw 10-32*3.2	4	YZGB7710-32*3.2N19
26	Weight Horn Plastic Cap	2	SL70012000	61	Nylon lock Nut M12	35	NM12DHS2
27	Aluminium Grip	2	SL70012100	62	Nylon lock Nut M10	1	NM10DHS2
28	Pull Spring	1	SL70012200	63	Nylon lock Nut M8	2	NM8DHS2
29	Idler Wheel	3	SL70012400	64	Flat Washer Φ 11* Φ 20*2	6	GB9510DHS2
30	Wring Spring	1	SL70012600	65	Flat Washer Φ 13* Φ 24*1.5	84	DQ12DHS2A
31	Shaft For Adjustable Handle	1	SL70012700	68	Hex key S=10	1	NBS10DHS
32	Oilite Bushing	2	M01402000	69	Hex key S=8	1	NBS8DHS
33	Ball Bearing	6	GB2766203-2Z	70	Hex key S=6	1	NBS6DHS
34	External Retaining Ring Φ 17	6	GB894.117FH12	71	Hex key S=4	1	NBS4DHS
35	Back Pad	1	SL70012900V1				

Exploded View

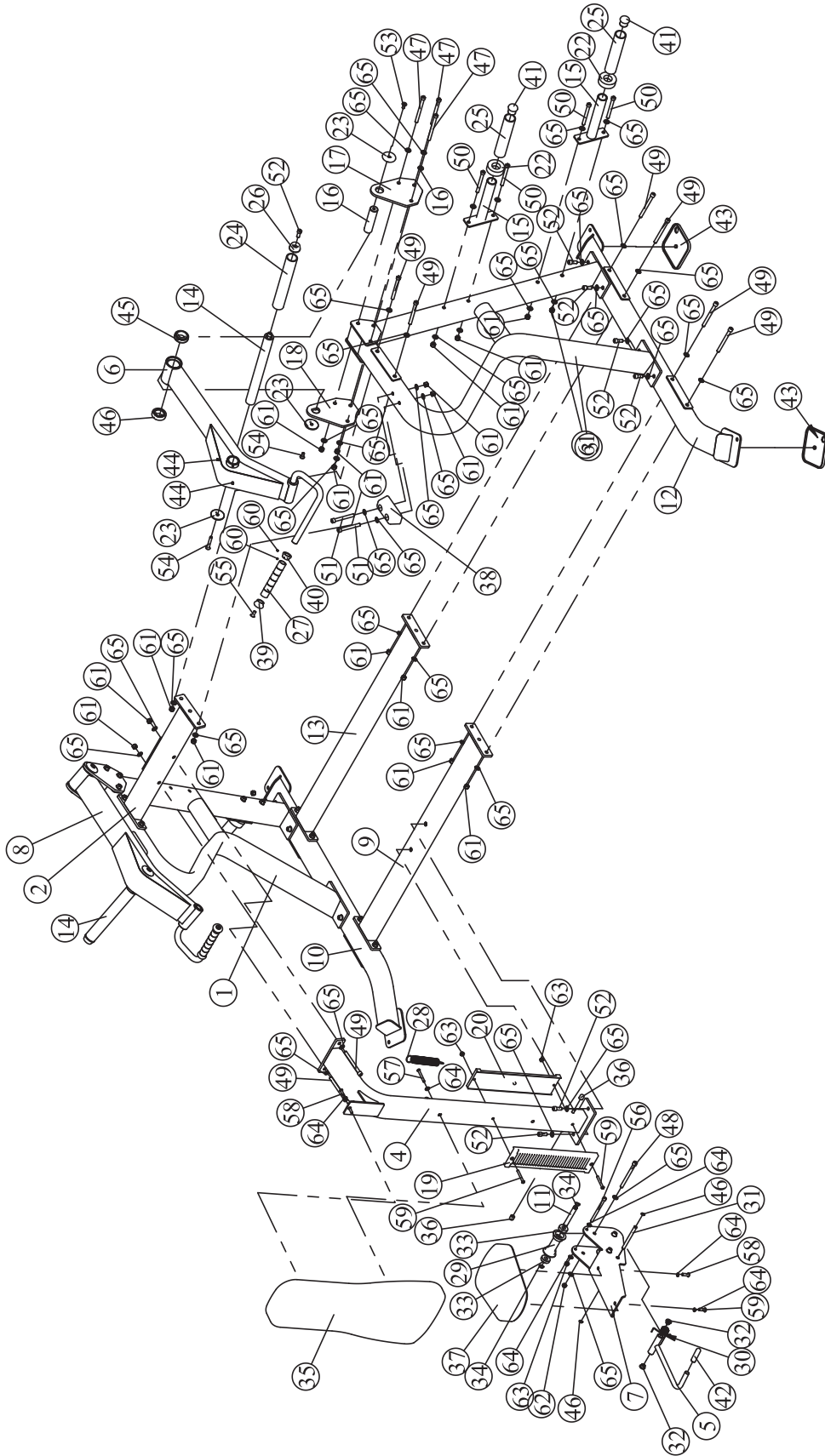

Measurement Guide

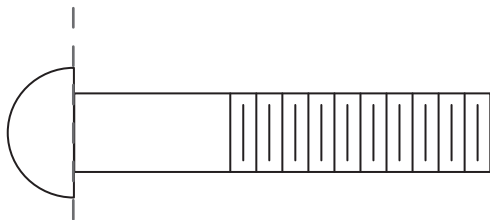

BHCS = Button Head Cap Screw

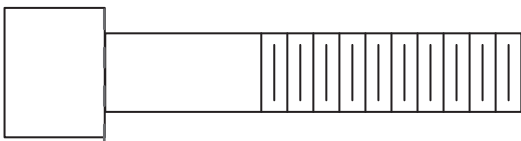

SHCS = Socket Head Cap Screw

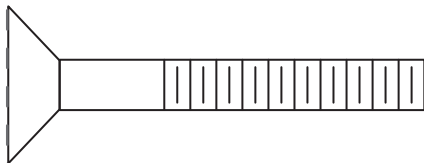

FHCS = Flat Head Cap Screw

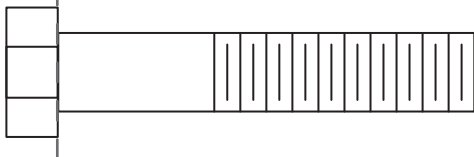

HHB = Hex Head Bolt

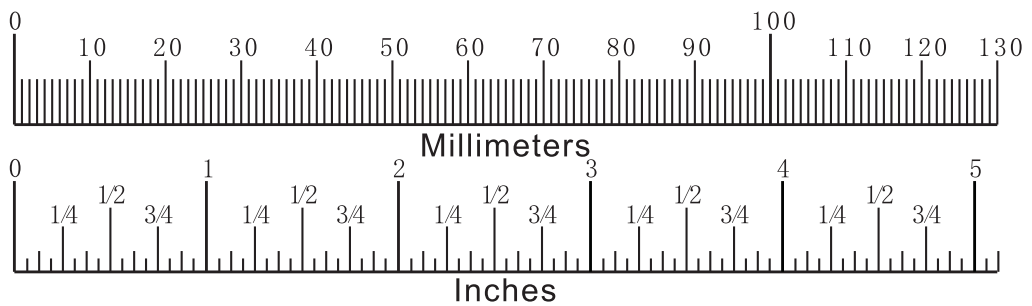

Assembly Instructions

Assembly of the equipment takes professional installers about 2 hours. If this is the first time you have assembled this type of equipment, plan to spend more time. It is strongly recommended to assemble the equipment by professional installers. You may find it quicker, safer, easier to assemble this equipment with the help of a friend, as some of components may be large, heavy or awkward to handle alone. It is important that you assemble your product in a clean, clear, uncluttered area. This will enable you to move around the product while you are fitting components and reduce the possibility of injury during assembly.



Note

As with any assembled part, proper alignment and adjustment is critical. While tightening the fasteners, be sure to leave room for adjustments. Do not fully tighten the fasteners until instructed to do so. Be careful to assemble the components in the sequence presented in this guide.

Assembly

Step 1

1. Attach the Left Bottom Frame (#10) to the Front Cross Frame (#9) and Rear Cross Frame (#13), using:

eight $\Phi 13 \times \Phi 24 \times 1.5$ Flat Washers (#65)

four M12*135 SHCS (#49)

four M12 Nylon lock Nuts (#61)

2. Attach the Right Bottom Frame (#12) to the Front Cross Frame (#9) and Rear Cross Frame (#13), using:

eight $\Phi 13 \times \Phi 24 \times 1.5$ Flat Washers (#65)

four M12*135 SHCS (#49)

four M12 Nylon lock Nuts (#61)

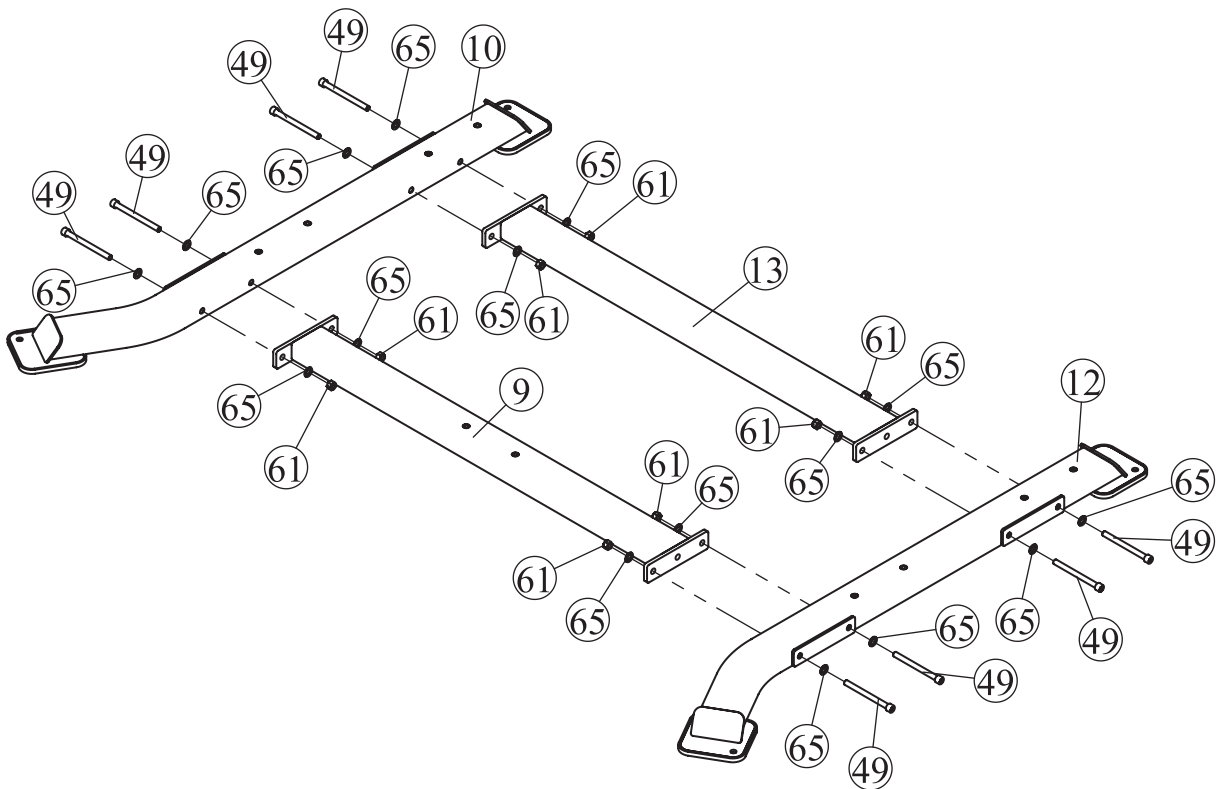

Assembly

Step 2

1. Attach the left Upright Frame (#1) to the Left Bottom Frame (#10), using:
four $\Phi 13*\Phi 24*1.5$ Flat Washers (#65) four M12*35 SHCS (#52)
2. Attach the Right Upright Frame (#3) to the Right Bottom Frame (#12), using:
four $\Phi 13*\Phi 24*1.5$ Flat Washers (#65) four M12*35 SHCS (#52)
3. Attach the Up Cross Frame (#2) to the left Upright Frame (#1) and the Right Upright Frame (#3), using:
eight $\Phi 13*\Phi 24*1.5$ Flat Washers (#65) four M12*135 SHCS (#49)
four M12 Nylon lock Nuts (#61)
4. Attach the Back Standing Frame (#4) to the Up Cross Frame (#2) and the Front Cross Frame (#9), using:
six $\Phi 13*\Phi 24*1.5$ Flat Washers (#65) two M12*135 SHCS (#49)
two M12 Nylon lock Nuts (#61) two M12*35 SHCS (#52)

NOTE: Tighten all the hardware.

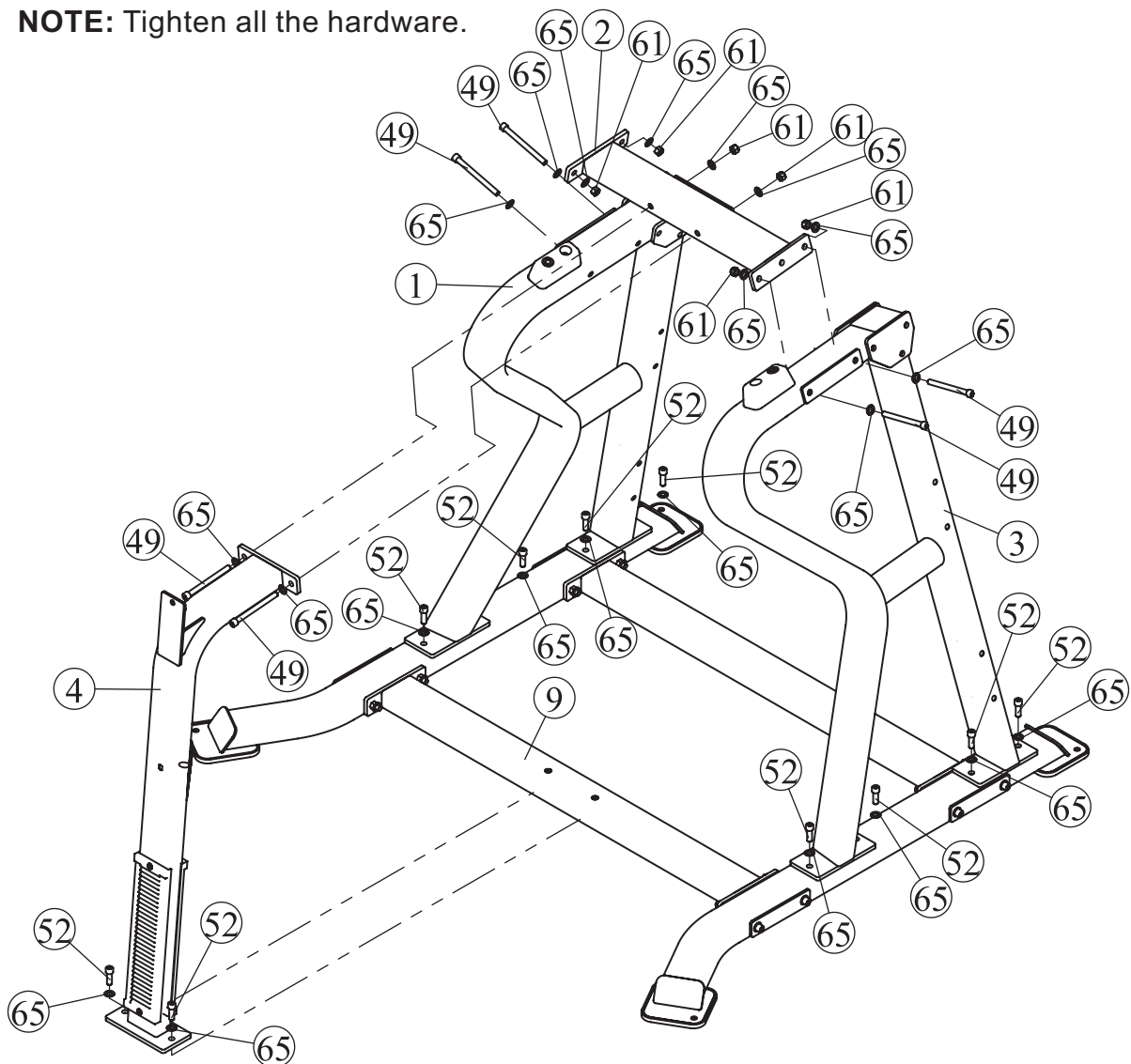

Assembly

Step 3

1. Attach the Left Arm Frame (#8) to the left Upright Frame (#1), using:
 - one $\Phi 30$ Pivot Shaft (#16)
 - one Pivot Plate 2 (D Type Hole) (#18)
 - six $\Phi 13 \times \Phi 24 \times 1.5$ Flat Washers (#65)
 - two Domed Aluminium Caps (#23)
 - one Pivot Plate 1 (#17)
 - three M12*155 SHCS (#47)
 - three M12 Nylon lock Nuts (#61)
 - two M12*30 FHCS (#53)
2. Attach the Right Arm Frame (#6) to the Right Upright Frame (#12), using:
 - one $\Phi 30$ Pivot Shaft (#16)
 - one Pivot Plate 2 (D Type Hole) (#18)
 - six $\Phi 13 \times \Phi 24 \times 1.5$ Flat Washers (#65)
 - two Domed Aluminium Caps (#23)
 - one Pivot Plate 1 (#17)
 - three M12*155 SHCS (#47)
 - three M12 Nylon lock Nuts (#61)
 - two M12*30 FHCS (#53)
3. Attach two Weight Horn Assembly (#14) to the Left Arm Frame (#6) and the Right Arm Frame (#7), using:
 - two Rubber Bumpers (#21)
 - two M12*50 FHCS (#54)
 - two Domed Aluminium Caps (#23)
 - four M8*6 Socket Set Screws (#44)
4. Attach four Weight Plate Storages (#15) to the left Upright Frame (#1) and the Right Upright Frame (#3), using:
 - sixteen $\Phi 13 \times \Phi 24 \times 1.5$ Flat Washers (#65)
 - eight M12*125 SHCS (#50)
 - eight M12 Nylon lock Nuts (#61)

Assembly

Step 3

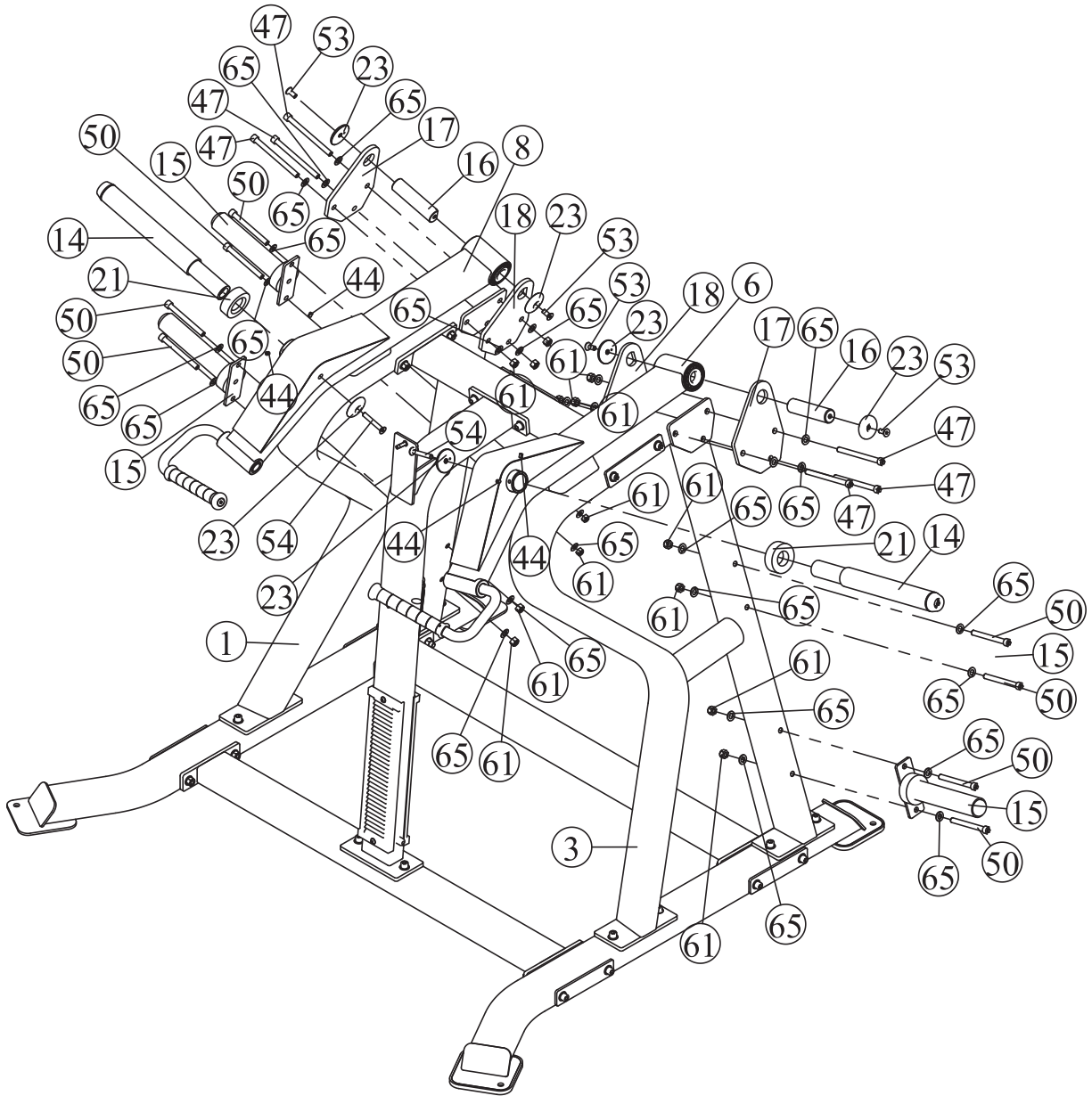

Assembly

Step 4

1. Attach the Seat Pad (#29) to the Seat Frame (#7), using:
two $\Phi 11 \times \Phi 20 \times 2$ Flat Washer (#64) two M10*30 BHCS (#58)
2. Attach the Seat Frame (#7) to the Back Standing Frame (#4), using:
two Idler Wheel Assemblies (#29) two M12*145 SHCS (#48)
four $\Phi 13 \times \Phi 24 \times 1.5$ Flat Washers (#65) two M12 Nylon lock Nuts (#61)
3. Attach the Back Pad (#35) to the Back Standing Frame (#4), using:
two $\Phi 11 \times \Phi 20 \times 2$ Flat Washer (#64) one M10*30 BHCS (#58)
one M10*75 BHCS (#57)
4. Attach the Pull Spring (#28) to the Back Standing Frame (#4), using:
two $\Phi 11 \times \Phi 20 \times 2$ Flat Washers (#64) one M10*145 SHCS (#56)
one M10 Nylon lock Nut (#62)

NOTE: Tighten all the hardware.

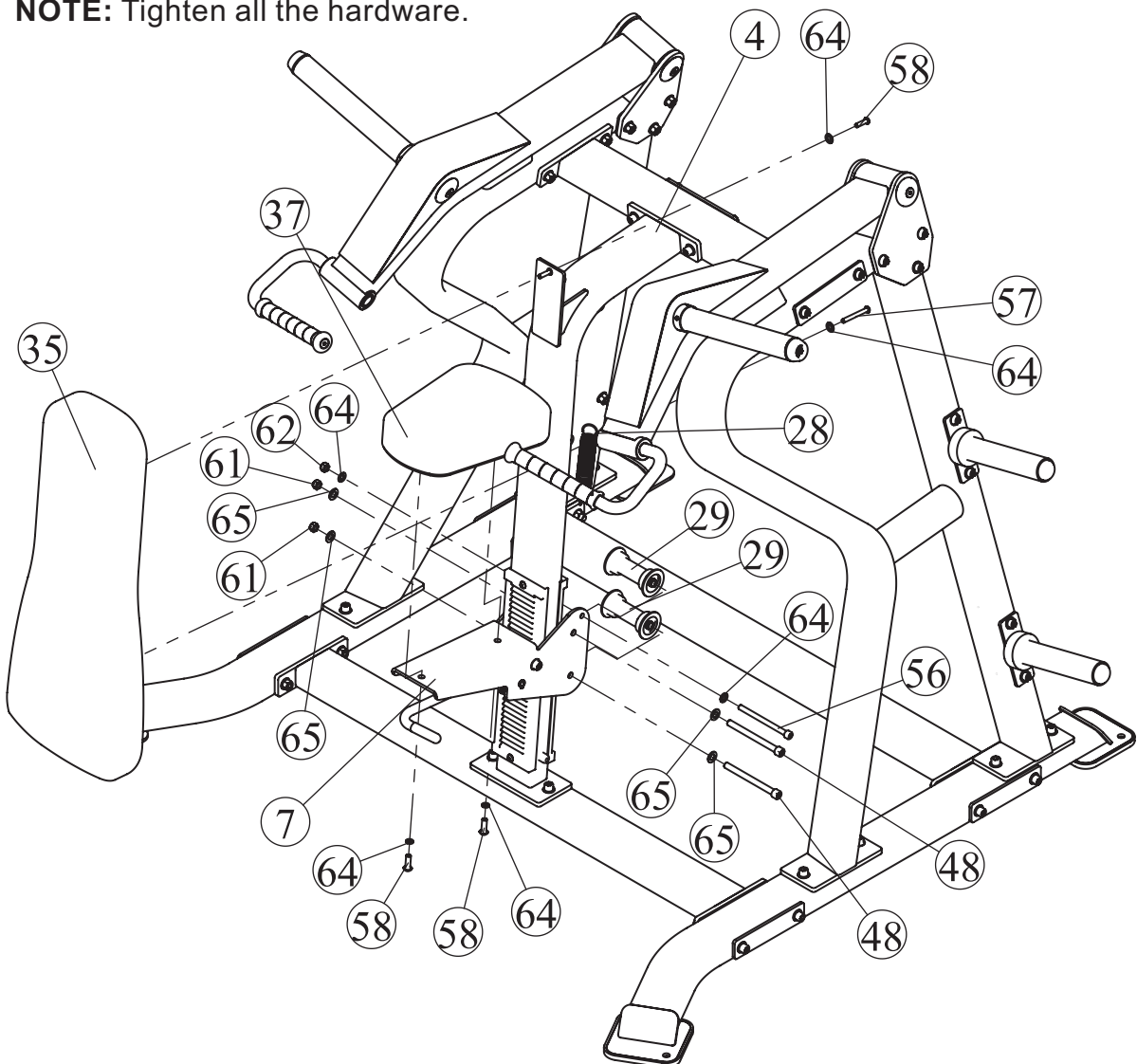

Maintenance Schedule

ROUTINE	COMMERCIAL MAINTENANCE	HOME MAINTENANCE	LATEST DATE ENTRY					
Inspect; Links, Pull Pins, Snap Locks, Swivels, Weight Stack Pins	DAILY	WEEKLY						
Clean; Upholstery	DAILY	WEEKLY						
Inspect; Cables or Belts and their tension	DAILY	WEEKLY						
Inspect; Accessory Bars, and Handles	WEEKLY	3 MONTHS						
Inspect; All Decals	WEEKLY	3 MONTHS						
Inspect; All Nuts and Bolts, Tighten if needed	WEEKLY	3 MONTHS						
Inspect; Anti-Skid Surface	WEEKLY	3 MONTHS						
Clean & Lubricate; Guide Rods with a Teflon (PTFE) based lubricant (Superlube)	MONTHLY	3 MONTHS						
Lubricate; Seat Sleeves, Turcite Bushings, Linear Bearing	MONTHLY	3 MONTHS						
Clean and Wax; All Glossy Finishes	6 MONTHS	YEARLY						
Repack with Grease; Linear Bearings	6 MONTHS	YEARLY						
Replace; Cables, Belts and Connecting Parts	YEARLY	3 YEARS						

Your equipment comes with a commercial maintenance decal. For personal, in home use, please follow the home maintenance schedule listed above.

General Maintenance Information

Links, Pull-Pins, Snap Hooks, Swivels, Weight Stack Pins:

- *Check all pieces for signs of visible wear or damage.
- *Check springs in snap hooks and pull-pins for proper tension and alignment.
- *If the spring sticks or has lost its rigidity, replace it immediately.

Upholstery:

- *To ensure prolonged upholstery life and proper hygiene, all upholstered pads should be wiped down with a damp cloth after every workout.
- *Periodically take the time to use a mild soap or an approved vinyl upholstery cleaner to deter the onset of cracking or drying. Avoid using any abrasive cleaners or cleaners not intended for use on vinyl.
- *Replace ripped or worn upholstery immediately.
- *Keep sharp or pointed objects clear of all upholstery.

Decals:

- *Inspect and familiarize yourself with any safety warnings or other user information posted on each decal.

Nuts and Bolts:

- *Inspect all nuts and bolts for any loosening and tighten if needed.
- *Go through a re-tightening sequence periodically to ensure that all hardware is tensioned proper.

Anti-Skid Surfaces:

- *These surfaces are designed to supply secure footing and need to be replaced if they appear worn or become slippery.

Belts and Cables:

- *We uses only high quality belt, and mil-spec cables.
- *Visually inspect the belts and cables for fraying, cracking, peeling or discoloration.
- *While the machine is not in use, carefully run your fingers along the belt or cable to feel for thinning or bulging areas.
- *Replace belts and cables immediately at the first signs of damage or wear. Do not use equipment until belts or cables have been replaced.

Belt and Cable Tension:

- *Referring to the Owners Manual, when belts or cables are used check all bolts attachments to be sure they are properly attached.
- *Check slack in cables and re-adjust cable tension if needed.

Seat Sleeves, Guide Rods:

- *Wipe down adjusting tubes with a dust free rag before applying lubricant.
- *Lubricate seat sleeves and Guide Rods with a Silicon or Teflon based lubricant spray.

Linear Bearings:

- *Referring to the Owners Manual carefully disassemble the bearing from its housing and place a finger full of light grease (lithium, super lube, etc.) into the inside of the bearing. Using your finger, press the grease into the ball-bearings and their tracks. repeat until the ball-bearing tracks are full of grease. Insert the shaft back into the bearing and wipe off excess grease.

PLEASE KEEP THIS FOR YOUR RECORDS

Weight Training Tips

Use this manual to guide you through the basic exercises you can perform on your equipment. To gain maximum results and avoid possible injury, consult a fitness professional to develop your complete exercise program.

Always consult your physician before starting any exercise program.

To be successful in your exercise program, it is important to develop an understanding of the basic principles of strength training. Now that you have your equipment, it is only natural that you want to get started immediately. First, determine a set of realistic goals and objectives for yourself. By deciding on an exercise plan that is right for you prior to starting, you will contribute significantly to your success.

Warm up properly before engaging in weight resistance training. Stretching, yoga, jogging, calisthenics or other cardiovascular exercise can help prepare your body for the heavier workload of lifting weights.

Learn how to perform the exercise correctly before using heavy weight. Correct form is important to avoid injury and to ensure that you work the proper muscle groups.

Know your limitations. If you are new to weight training or are embarking on an exercise regimen after a long layoff, start slowly and build foundational strength over a longer period of time.

Pay attention to your breathing. Exhale when you exert is a general rule of thumb. Never hold your breath.

Specifications

Class: S

Maximum Wt.Capacity: 300Kg/660lbs

