



SL7034

SQUAT

OWNER'S MANUAL

23F

CAUTION! Read all precautions and instructions in this manual before using this equipment.

! CAUTION

Read all precautions and instructions in this manual before using this equipment.

Table Of Contents

Important Safety Instructions-----	3
Instructions-----	5
Parts List and Exploded View-----	6
Measurement Guide-----	16
Assembly Instructions-----	17
Assembly-----	18
Exercise Instructions and Adjust Instructions-----	21
Maintenance Schedule-----	22
General Maintenance Information-----	23
Weight Training Tips-----	24

Important Safety Instructions

Before beginning any fitness program, you should obtain a complete physical examination from your physician. When using exercise equipment, basic precautions should always be taken, including the following:

1. Read all instructions before using the equipment.
These instructions are written to ensure your safety and to protect the unit.
2. Use the equipment only for its intended purpose as described in this guide.
Do not use accessory attachments that are not recommended by the manufacturer: such attachments might cause injuries.
3. The product should only be used on a level surface and is with 0.6 meters space around the product.
Do not use the equipment outdoors.
4. Do not allow children on or near the equipment. And children are not allowed to use this equipment.
Teenagers should use this equipment with adult supervision.
5. Do not overexert yourself or work to exhaustion.
Do not attempt to lift more weight than you can control safely.
If you feel any pain or abnormal symptoms, stop your workout immediately and consult your physician.
6. This equipment is not used as medical apparatus and instruments.
7. Never operate the unit when it has been dropped or damaged.
Never drop or insert anything into any opening in the equipment.
Always check the unit and its cables before each use. Make sure that all fasteners and cables are secure and in good working condition.
Frayed or worn cables can be dangerous and may cause injury. Periodically check these cables for any indication of wear.
Keep hands, limbs, loose clothing and long hair well out of the way of moving parts.
8. Be careful when getting on or off the equipment.
9. Wear proper exercise clothing and shoes for your workout, no loose clothing.

Important Safety Instructions

Personal Safety During Assembly

Read each step in the assembly instructions and follow the steps in sequence. Do not skip ahead. If you skip ahead, you may learn later that you have to disassemble components and that you may have damaged the equipment.

Assemble and operate the equipment on a solid, level surface. Locate the unit a few feet from walls or furniture to provide easy access. The equipment is designed for your enjoyment. By following these precautions and using common sense, you will have many safe and pleasurable hours of healthful exercise with the equipment.

Training Area and Free Area

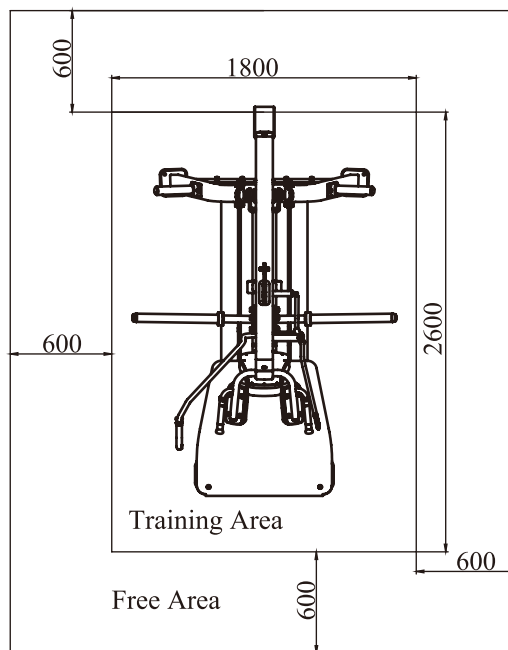

Specifications

Class: S

Maximum Wt. Capacity: 400kg/ 880lbs

Maximum User Weight: 150kg/ 330lbs

Product Total Surface: 2300*1600mm

Product Total Mass: 212kg/ 467lbs

Instructions

Before beginning assembly please take the time to read instructions thoroughly. Please use the various lists in this manual to make sure that all parts have been included in your shipment. When ordering, use part number and description from the lists. Use only our replacement part when servicing. Failure to do so will void your warranty and could result in personal injury.

The equipment is designed to provide the smoothest, most effective exercise motion possible. After assembly, you should check all functions to ensure correct operation. If you experience problems, first recheck the assembly instructions to locate any possible errors made during assembly. If you are unable to correct the problem, call your authorized dealer. Be sure to have your serial number and this manual when calling. When all parts have been accounted for, continue on.

Tools Required

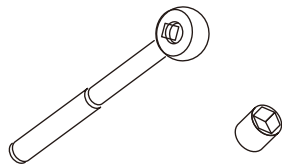

Ratchet Wrench and Socket

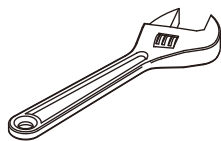

Adjustable Wrench

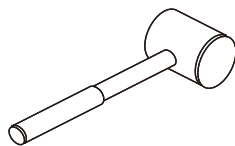

Rubber Mallet

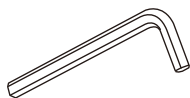

Hex Key Wrench Set

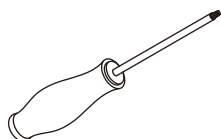

Phillips Screwdriver

Parts List and Exploded View

Back Frame ASSY

ItemNo.	Grade No.	Part No.	Description	QTY
1	5.2.1	SL70340600	Back Frame	1
2	5.2.2	SL70341000	L Handle Frame	1
3	5.2.3	SL70342200	Plastic End Cap	2
4	5.2.4	SL70342600	Shaft Bushing	1
5	5.2.5	SL70342700	Pin Shaft	1
6	5.2.6	SL70342800	Slide Shaft	1
7	5.2.7	SL70342900	Thick Spring	1
8	5.2.8	SL70343000	Liny Spring	1
9	5.2.9	SL70343100	Locknut	1
10	5.2.10	HVCORE5300	Bushing Φ 19	2
11	5.2.11	VLP8000	End Cap \square 50*100	2
12	5.2.12	BNH0547	Slide Pad	2
13	5.2.13	SL70012100	Aluminum Grip	2
14	5.2.14	IT90102200	Aluminum Ring Φ 25	2
15	5.2.15	IT90102100	Aluminum Cap Φ 25	2
16	5.2.16	FE970114100	Upper Regulation Cover	1
17	5.2.17	FE970114200	Lower Regulation Cover	1
19	5.2.19	IF81165000	Nut M10	2
20	5.2.20	GB/T1243-199708B	Link	1
21	5.2.21	GB70M10*80DHS20	Socket Head Cap Screw M10*80	1
22	5.2.22	CNLM10*35*35DS20	Flat Head Cap Screw M10*35	2
23	5.2.23	CNLM10*25DHS20	Flat Head Cap Screw M10*25	2
24	5.2.24	GB819M4*8DN2	Screw M4*8	2
25	5.2.25	GB818M4*16DN2NL	Screw M4*16	1
26	5.2.26	YZGB7710-32*3.2DS2	Socket Set Screw 10-32*3.2	4
27	5.2.27	GB41M4DN2	Hexagon Nut M4	1
28	5.2.28	NM10DHS2	Nylon Nut M10	1
29	5.2.29	DQ10DHS2A	Flat Washer Φ 11* Φ 20*2	2

Parts List and Exploded View

Back Frame ASSY

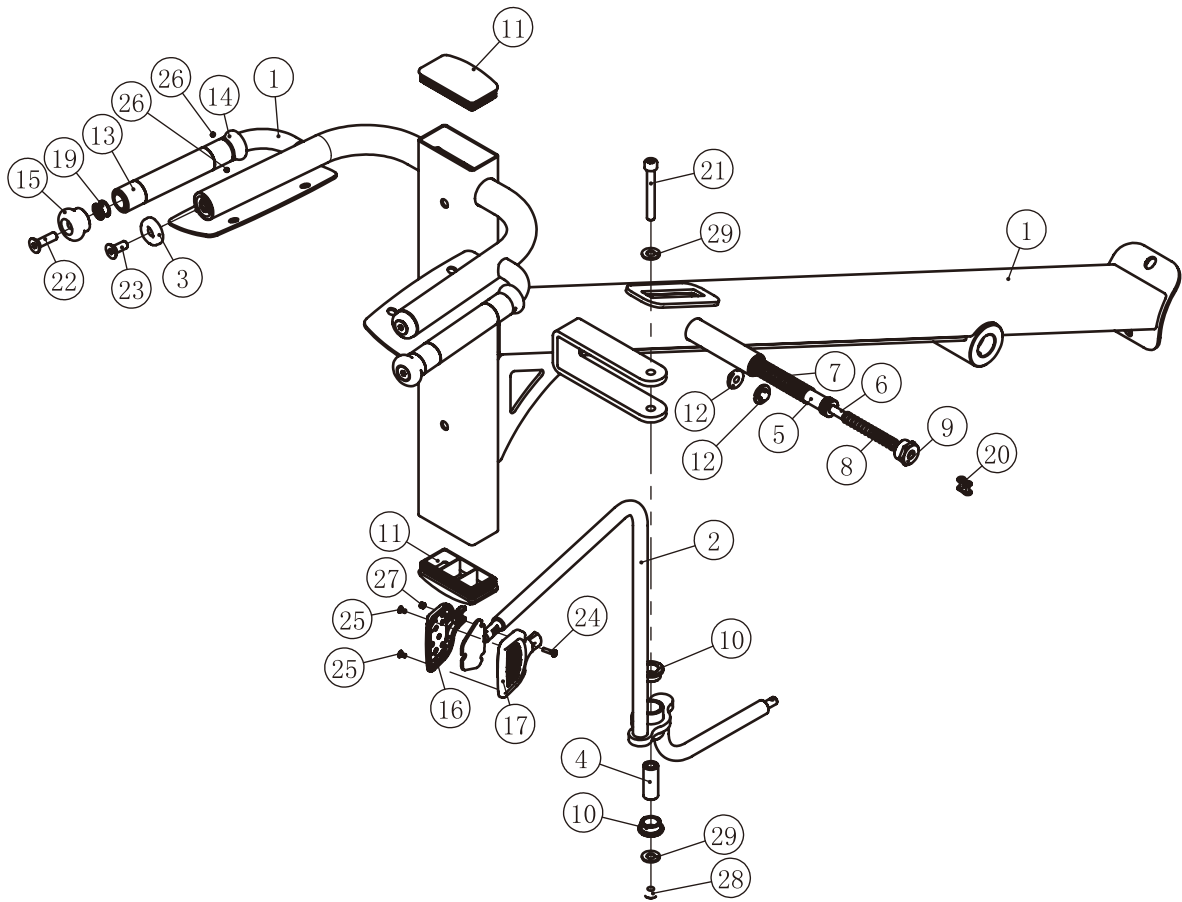

Parts List and Exploded View

Bottom Frame ASSY

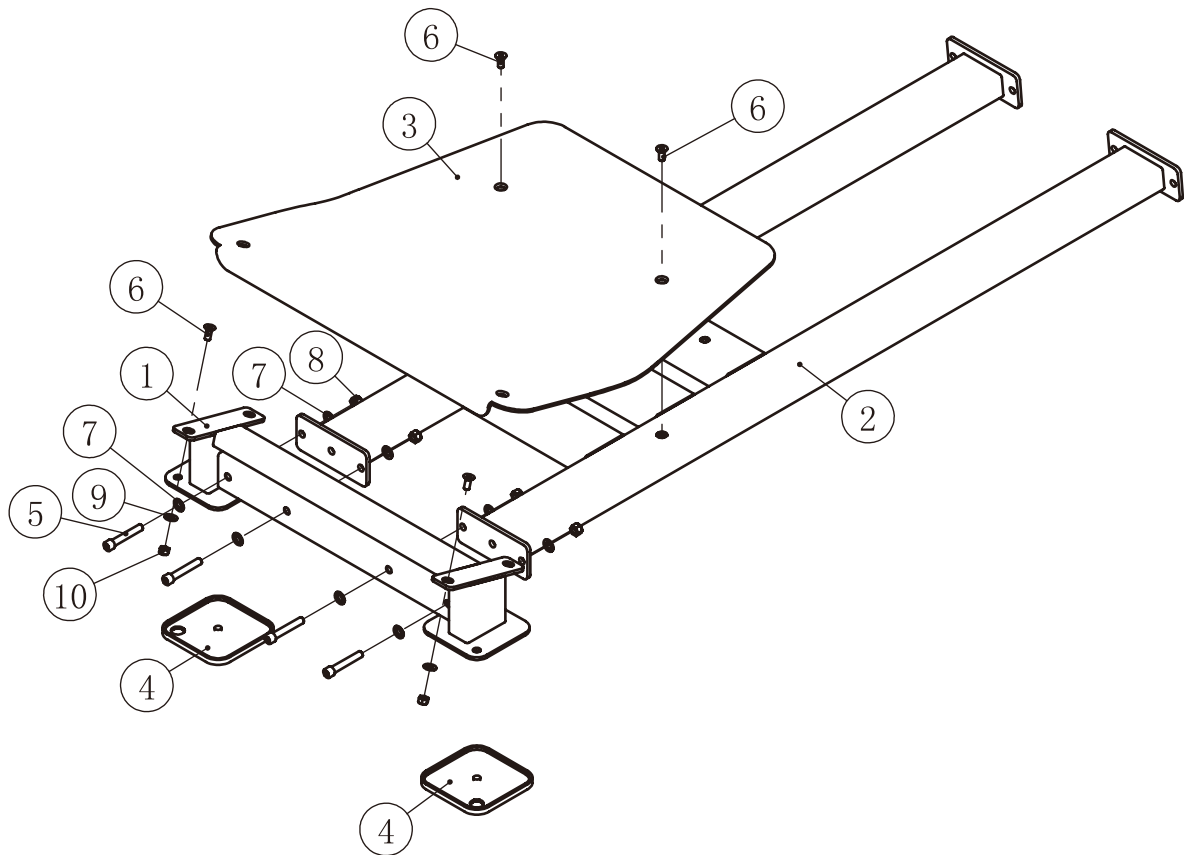

ItemNo.	Grade No.	Part No.	Description	QTY
1	1.1	SL70340100	Front Frame	1
2	1.2	SL70340300	Bottom Frame	1
3	1.3	SL70341200	Pedal	1
4	1.4	CWRVL0051200	Rubber Foot	2
5	1.5	GB70M12*75DHS20	Socket Head Cap Screw M12*75	4
6	1.6	CNLM10*25DHS20	Flat Head Cap Screw M10*25	4
7	1.7	DQ12DHS2A	Flat Washer $\Phi 13 * \Phi 24 * 1.5$	8
8	1.8	NM12DHS2	Nylon Nut M12	4
9	1.9	DQ10DHS2A	Flat Washer $\Phi \Phi 11 * \Phi 23 * 2$	2
10	1.10	NM10DHS2	Nylon Nut M10	2

Parts List and Exploded View

Long WT Bar ASSY

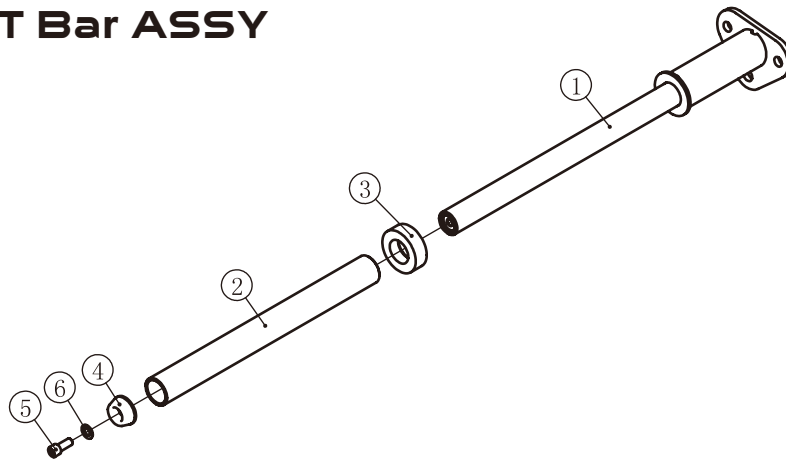

ItemNo.	Grade No.	Part No.	Description	QTY
1	4.1	SL70340700	Long WT Bar	1
2	4.2	SL70063800	Long Weight Horn Sleeve	1
3	4.3	HF985A1500	Weight Horn Rubber Donut Φ 76	1
4	4.4	SL70012000	End Plug	1
5	4.5	GB70M12*30DHS20NL	Socket Head Cap Screw M12*30	1
6	4.6	DQ12DHS2A	Flat Washer Φ 13* Φ 24*1.5	1

R Handle Frame ASSY

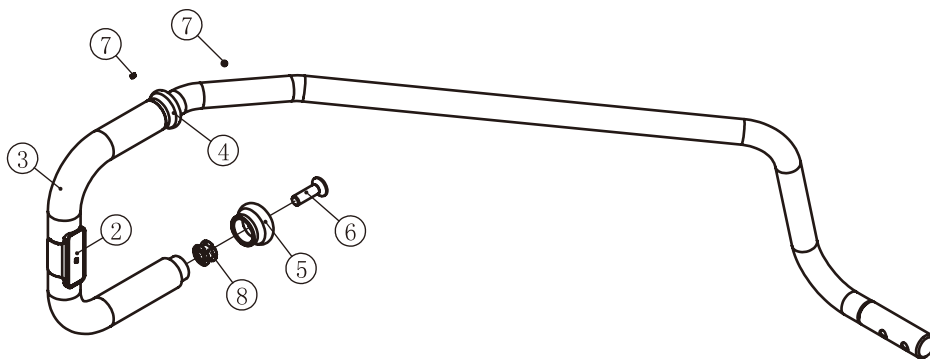

ItemNo.	Grade No.	Part No.	Description	QTY
1	7.1	SL70341100	R Handle Frame	1
2	7.2	SL70343400	Clasp	1
3	7.3	FS533300	Grip	1
4	7.4	IT90102200	Aluminum Ring Φ 25	1
5	7.5	IT90102100	Aluminum Cap Φ 25	1
6	7.6	CNLM10*35*35DS20	Flat Head Cap Screw M10*35	1
7	7.7	YZGB7710-32*3.2DS2	Socket Set Screw 10-32*3.2	2
8	7.8	IF81165000	Nut M10	1

Parts List and Exploded View

Rear Stand Frame ASSY

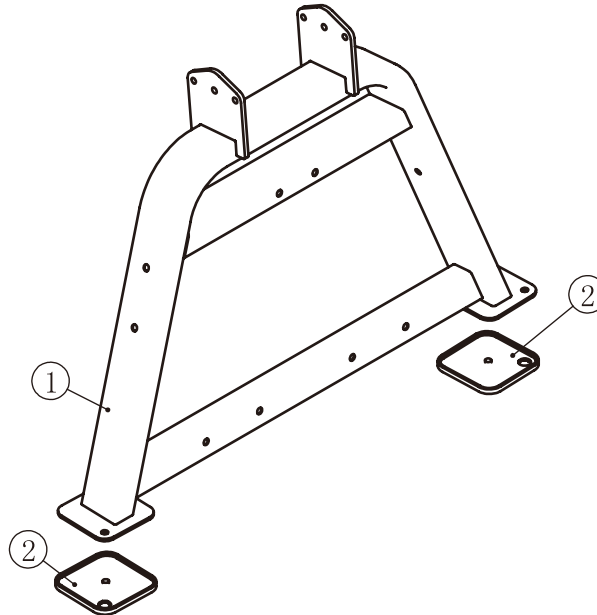

ItemNo.	Grade No.	Part No.	Description	QTY
1	2.1	SL70340200	Rear Stand Frame	1
2	2.2	CWRVL0051200	Rubber Foot	2

WT Bar ASSY

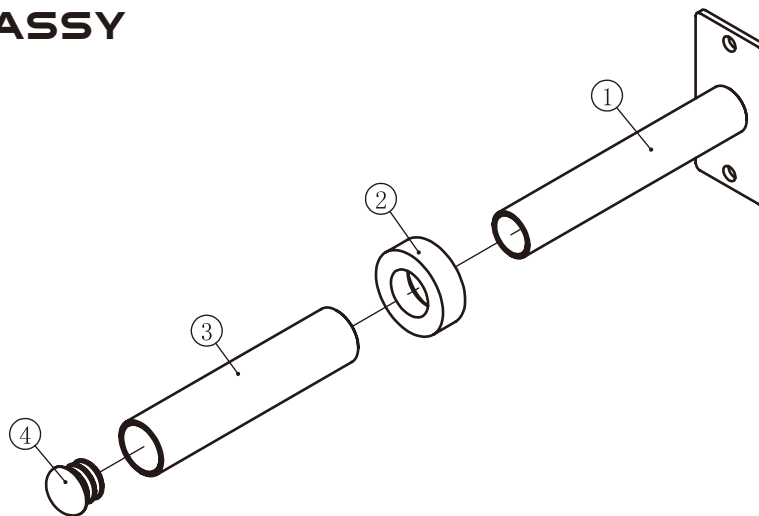

ItemNo.	Grade No.	Part No.	Description	QTY
1	6.1	SL70340900	WT Bar	1
2	6.2	HF985A1500	Weight Horn Rubber Donut Φ 76	1
3	6.3	SL70100400	Weight Horn Sleeve	1
4	6.4	RF-6012500	End Plug	1

Parts List and Exploded View

Support Frame ASSY

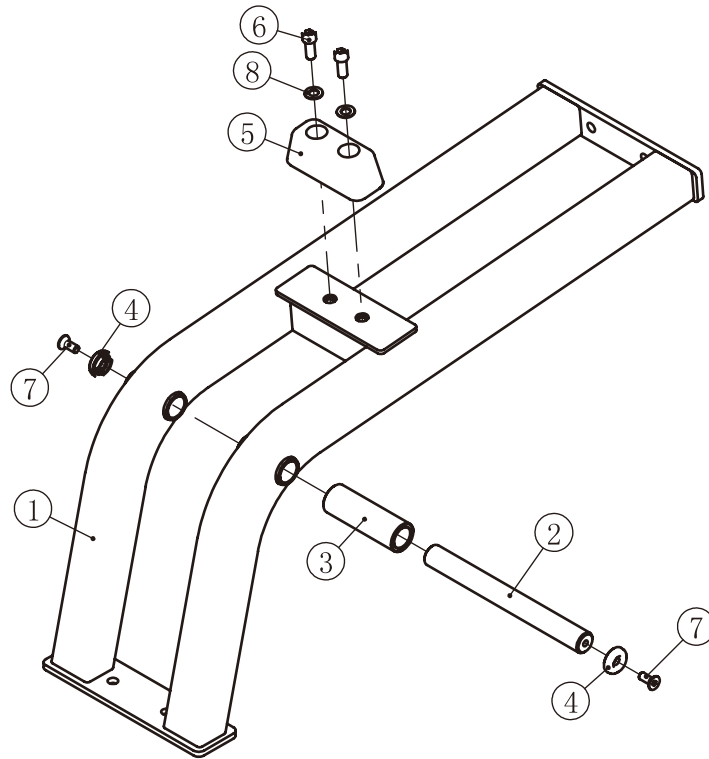

ItemNo.	Grade No.	Part No.	Description	QTY
1	3.1	SL70340400	Support Frame	1
2	3.2	SL70341300	Stop Shaft	1
6	3.3	SL70341400	Stop Collar	1
3	3.4	SL70342200	Plastic End Cap	2
4	3.5	PL380800	Crash Pad	1
5	3.6	CNLM10*25DHS20	Flat Head Cap Screw M10*25	2
7	3.7	GB70M12*30DHS20NL	Socket Head Cap Screw M12*30	2
8	3.8	DQ12DHS2A	Flat Washer $\Phi 13 * \Phi 24 * 1.5$	2

Parts List and Exploded View

WT Frame ASSY

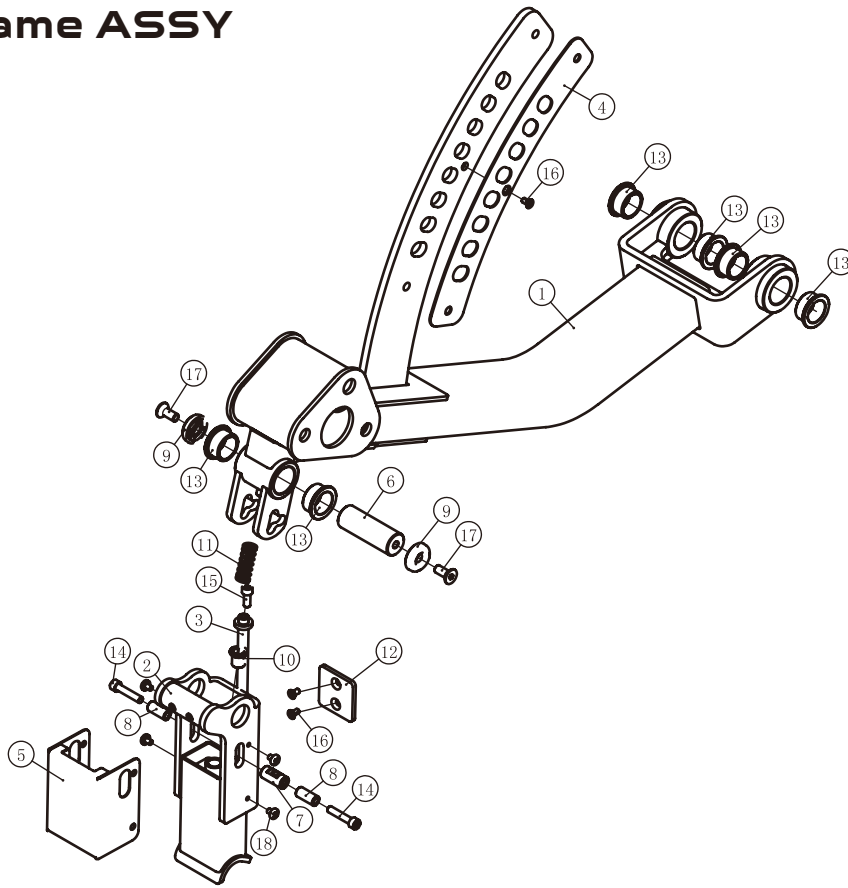

ItemNo.	Grade No.	Part No.	Description	QTY
1	5.1.1	SL70340500	WT Frame	1
2	5.1.2	SL70340800	Support Frame	1
3	5.1.3	SL70341600	Slide Shaft	1
4	5.1.4	SL70341700	Stainless Steel Pplate	1
5	5.1.5	SL70341800	Shield	1
6	5.1.6	SL70341900	Pin Shaft	1
7	5.1.7	SL70342000	Stop Shaft	1
8	5.1.8	SL70342100	Stop Collar	2
9	5.1.9	SL70342200	Plastic End Cap	2
10	5.1.10	SL70342300	Bushing Φ 12.7	1
11	5.1.11	SL70342500	Spring	1
12	5.1.12	DBR06102500	Plastic Plate	1
13	5.1.13	FS573600	Bushing Φ 30	6
14	5.1.14	GB70M8*40DHS20	Socket Head Cap Screw M8*40	2
15	5.1.15	GB70M8*20DHS20NL	Socket Head Cap Screw M8*20	1
16	5.1.16	CNLM6*12DHS20NL	Flat Head Cap Screw M6*12	3
17	5.1.17	CNLM10*25DHS20	Flat Head Cap Screw M10*25	2
18	5.1.18	GB818M6*8DHS2	Screw M6*8	4

Parts List and Exploded View

WT & Back Frame ASSY

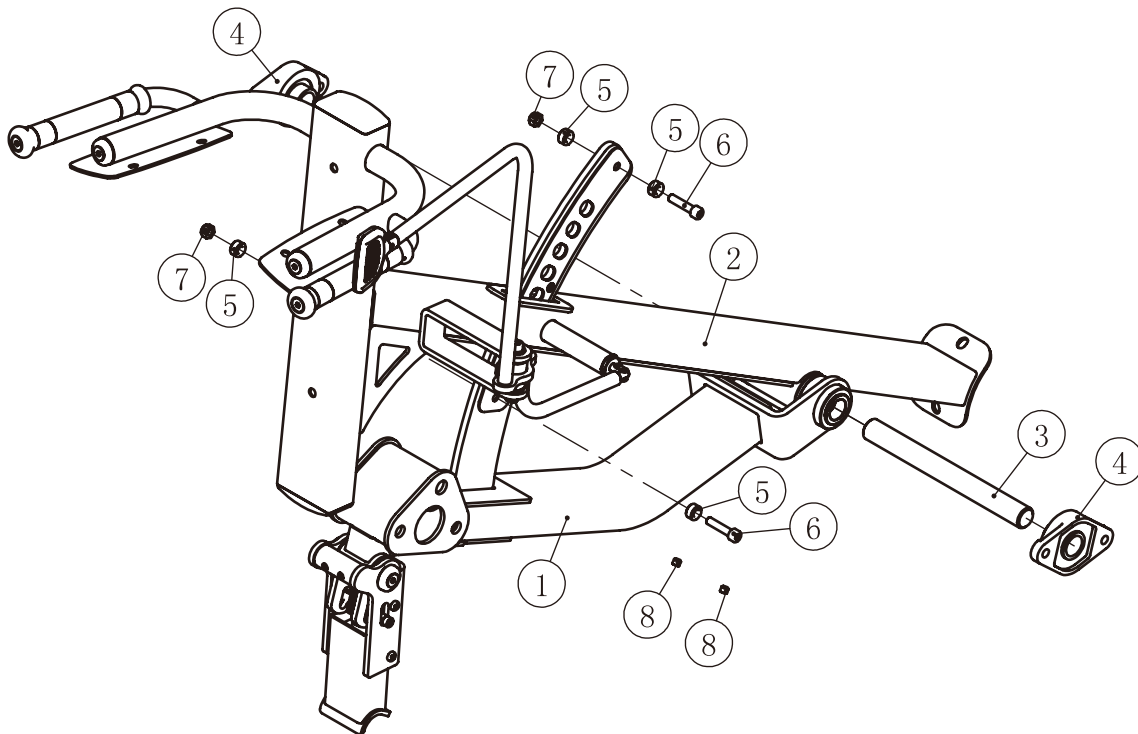

ItemNo.	Grade No.	Part No.	Description	QTY
1	5.1	SL703405ASSY	WT Frame ASSY	1
2	5.2	SL703406ASSY	Back Frame ASSY	1
3	5.3	SL70343300	Shaft	1
4	5.4	UCFLU206	Pillow Block Bearing	2
5	5.5	ODY510400	Nylon Spacer	4
6	5.6	GB70M10*45DHS4	Socket Head Cap Screw M10*45	2
7	5.7	NM10DHS2	Nylon Nut M10	2
8	5.8	GB77M10*8DS18	Socket Set Screw M10*8	2

Parts List and Exploded View

Overall

Item No.	Part No.	Description	QTY
1	SL703401ASSY	Bottom Frame ASSY	1
2	SL703402ASSY	Rear Stand Frame ASSY	1
3	SL703404ASSY	Support Frame ASSY	1
4	SL703407ASSY	Long WT Bar ASSY	2
5	SL703408ASSY	WT & Back Frame ASSY	1
6	SL703409ASSY	WT Bar ASSY	2
7	SL703411ASSY	R Handle Frame ASSY	1
8	SL70343600	Back Pad	1
9	SL70343700	Shoulder Pad	2
10	SL70343500	Balancing Weight	1
13	GB70M16*155*50DHS20	Socket Head Cap Screw M16*155	3
14	GB70M12*30DHS20NL	Socket Head Cap Screw M12*30	4
15	GB70M12*40DHS20	Socket Head Cap Screw M12*40	4
16	GB70M12*75DHS20	Socket Head Cap Screw M12*75	8
17	GB70M12*130DHS20	Socket Head Cap Screw M12*130	2
18	GB70M10*25DHS20NL	Socket Head Cap Screw M10*25	2
19	PNLM10*70DHS2	Button Head Cap Screw M10*70	2
20	PNLM10*25DHS20	Button Head Cap Screw M10*25	8
21	GB9310DHS12	SPLIT LOCK WASHER Φ 10	2
22	YDQ16.5*28*2DHS2	Flat Washer Φ 16.5* Φ 28*2	6
23	NM16DHS2	Nylon lock Nut M16	3
24	DQ12DHS2A	Flat Washer Φ 13* Φ 24*1.5	32
25	NM12DHS2	Nylon lock Nut M12	14
26	DQ10DHS2A	Flat Washer Φ 11* Φ 23*2	10
27	NBS14DHS	Hex Key S=14	1
28	NBS10DHS	Hex Key S=10	1
29	NBS8DHS	Hex Key S=8	1
30	NBS6DHS	Hex Key S=6	1
31	GB9312DHS12	SPLIT LOCK WASHER Φ 12	2

Parts List and Exploded View

Overall

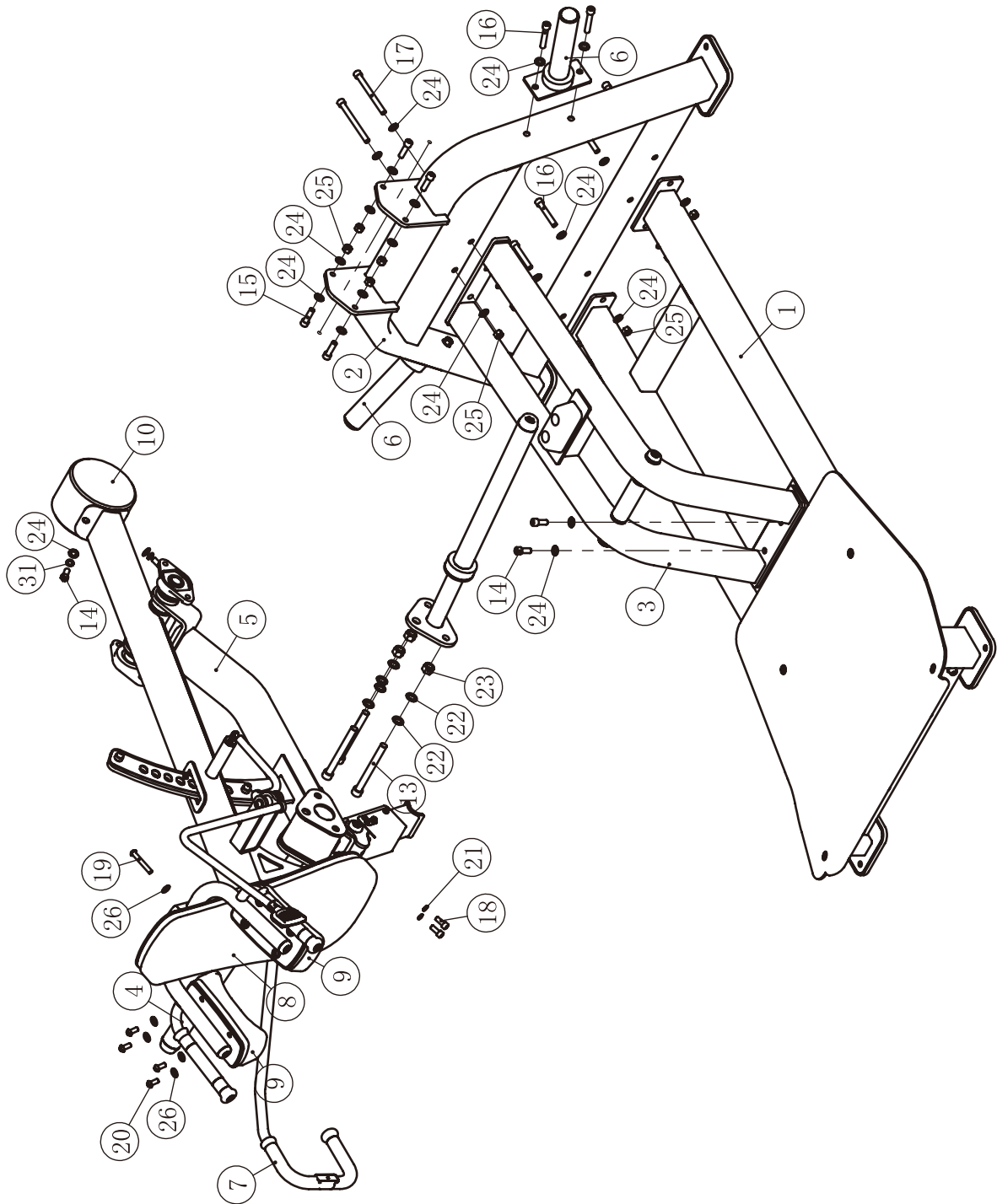

Measurement Guide

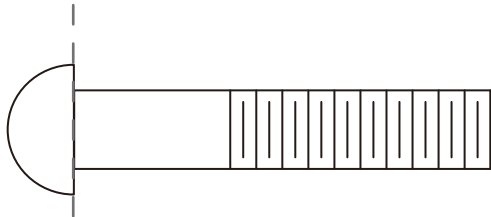

BHCS = Button Head Cap Screw

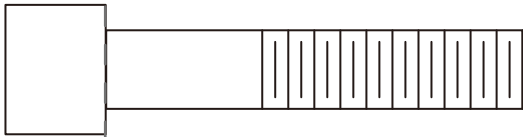

SHCS = Socket Head Cap Screw

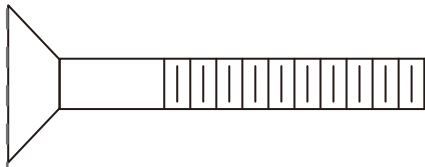

FHCS = Flat Head Cap Screw

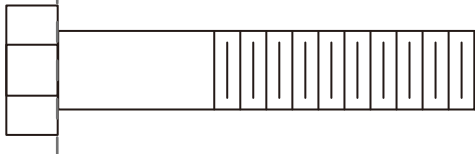

HHB = Hex Head Bolt

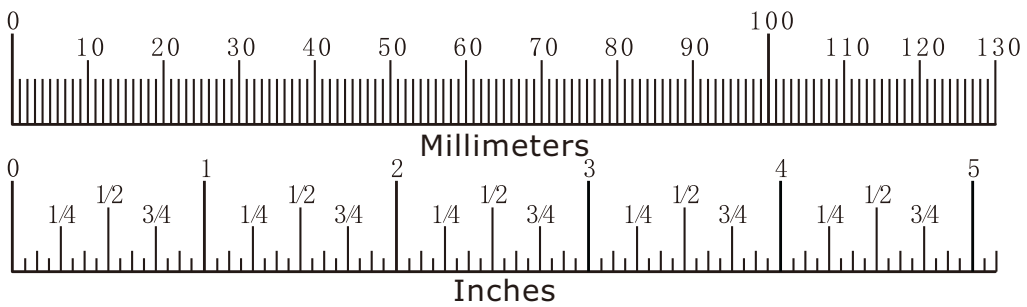

Diameter of bolt (mm/inch)	M6(1/4")	M8(5/16")	M10(3/8")	M12(1/2")	M16(5/8")
Tightening torque (N.m)	9~12	22~30	45~59	78~104	193~257
Operational methods for adult men	The strength of the wrist	The strength of the wrist and forearm	The strength of the entire arm	The strength of the arm and upper body	with all strength

Assembly Instructions

Assembly of the equipment takes professional installers about 2 hours. If this is the first time you have assembled this type of equipment, plan to spend more time. It is strongly recommended to assemble the equipment by professional installers. You may find it quicker, safer, easier to assemble this equipment with the help of a friend, as some of components may be large, heavy or awkward to handle alone. It is important that you assemble your product in a clean, clear, uncluttered area. This will enable you to move around the product while you are fitting components and reduce the possibility of injury during assembly.

NOTE

As with any assembled part, proper alignment and adjustment is critical. While tightening the fasteners, be sure to leave room for adjustments. Do not fully tighten the fasteners until instructed to do so. Be careful to assemble the components in the sequence presented in this guide.

Assembly

Step 1

Attach Rear Stand Frame ASSY (#2), Support Frame ASSY (#3) to Bottom Frame ASSY (#1), using:

- two M12*30 SHCS (#14)
- eight M12*75 SHCS (#16)
- two M12*130 SHCS (#17)
- ten M12 Nylon lock Nuts (#25)
- twenty-two $\Phi 13*\Phi 24*1.5$ Flat Washers (#24)

Note: Tighten the hardware.

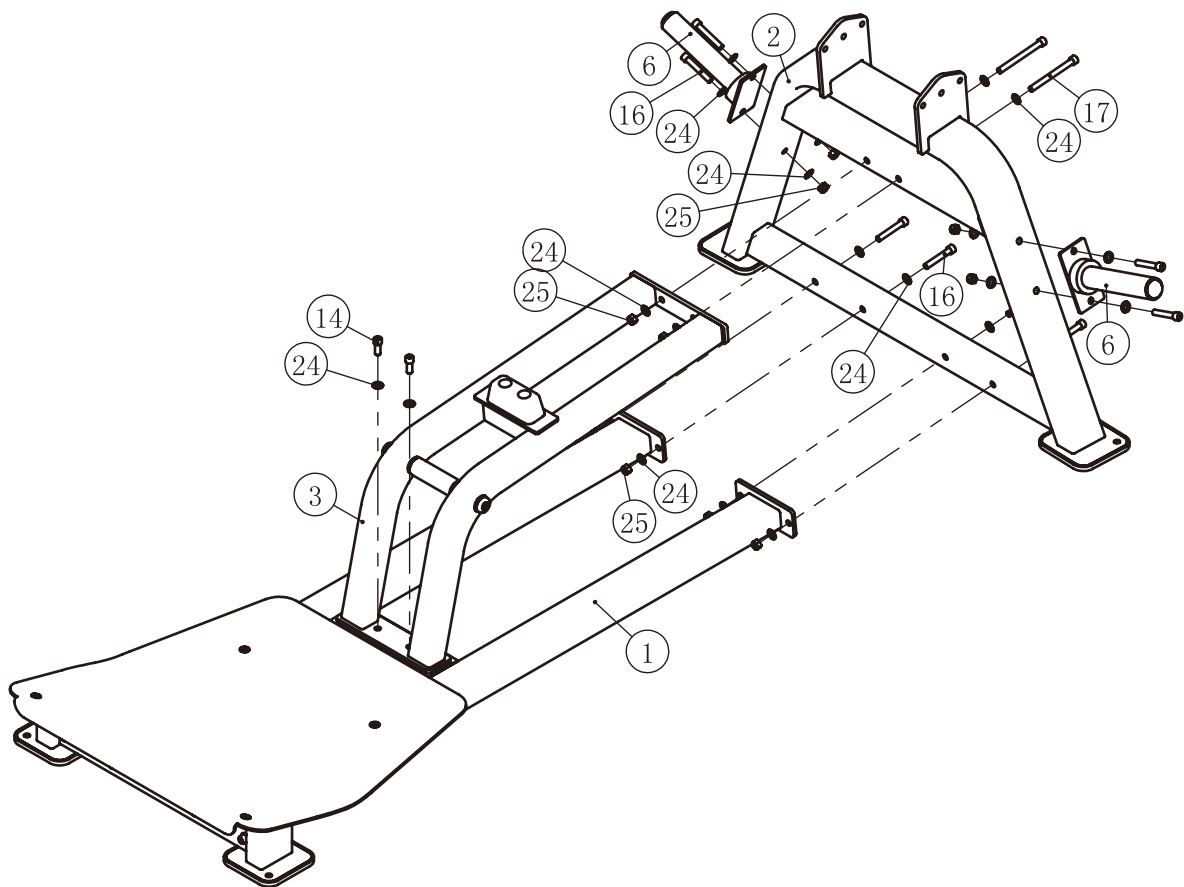

Assembly

Step 2

Fit WT & Back Frame ASSY on, using:

- four M12*40 SHCS (#15)
- four M12 Nylon lock Nuts (#25)
- eight $\Phi 13*\Phi 24*1.5$ Flat Washers (#24)

Note: Tighten the hardware.

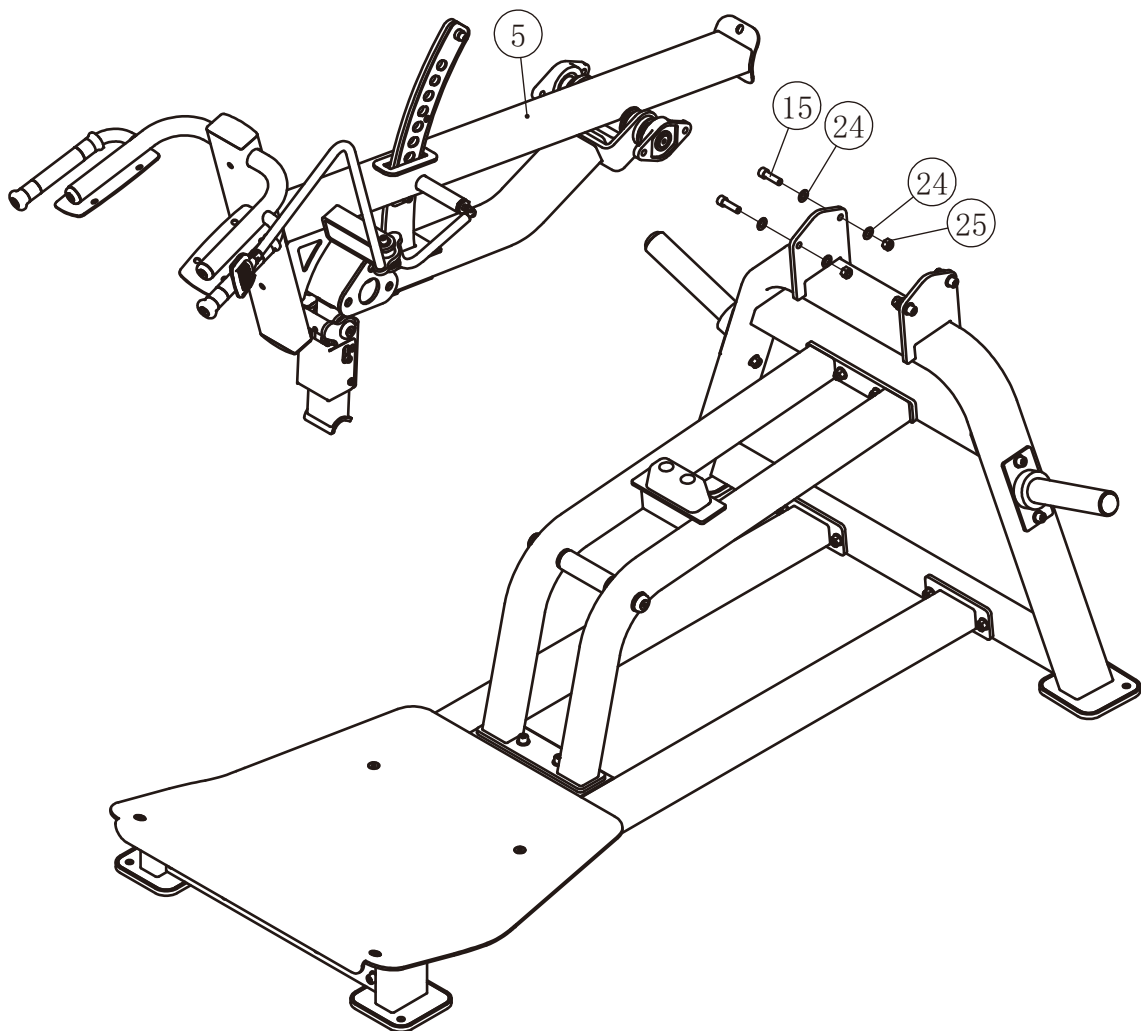

Assembly

Step 3

1. Attach R Handle Frame ASSY (#7) to WT & Back Frame ASSY, using:
 - two M10*25 SHCS (#18)
 - two $\Phi 10$ spring washer (#21)
2. Attach Long WT Bar ASSY (#4) to WT & Back Frame ASSY, using:
 - three M16*155 SHCS (#13)
 - six $\Phi 28*\Phi 16.5*2$ Flat Washers (#22)
 - three M16 Nylon lock Nuts (#23)
3. Attach Back Pad (#8), Back Pad (#9), Balancing Weight (#10) to WT & Back Frame ASSY, using:
 - two M12*30 SHCS (#14)
 - two $\Phi 12$ Split Lock Washer (#31)
 - two M10*70 BHCS (#17)
 - eight M10*25 BHCS (#20)
 - two $\Phi 13*\Phi 24*1.5$ Flat Washers (#24)
 - ten $\Phi 10*\Phi 20*2$ Flat Washers (#26)

Note: Wrench Tighten Bolts and Nylon Lock Nuts.

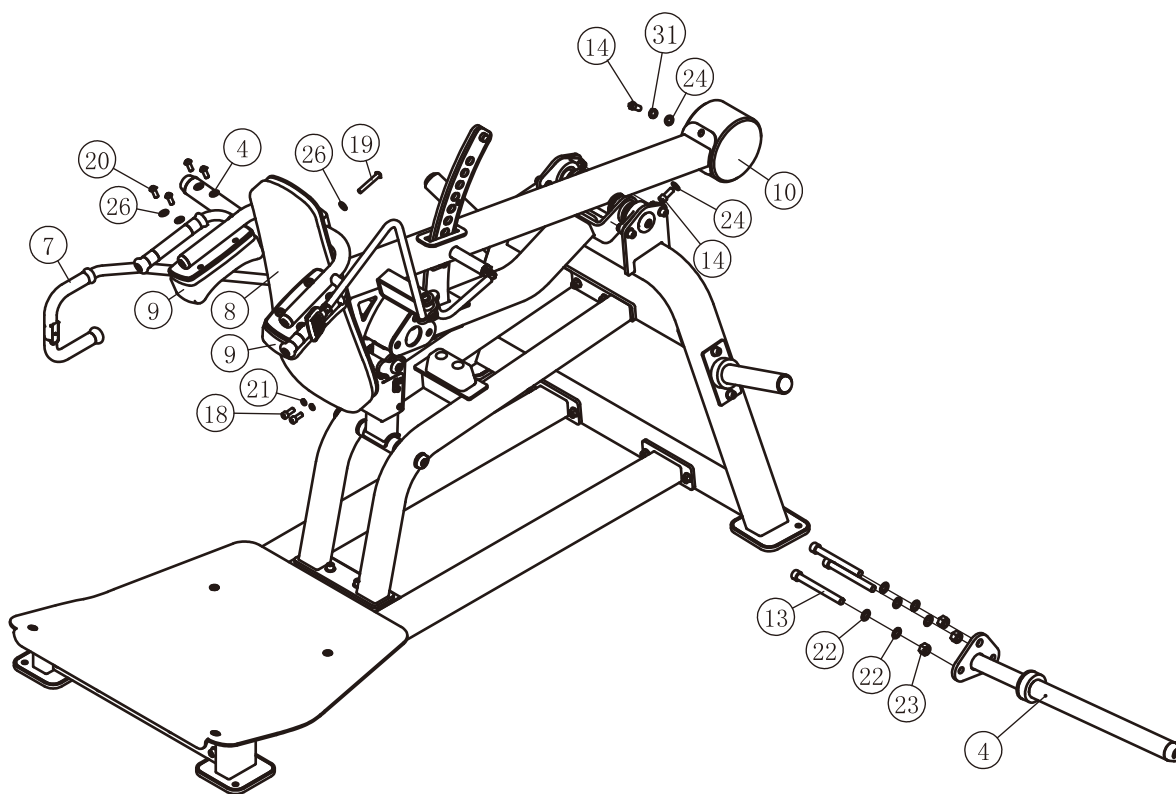

Exercise Instructions and Adjust Instructions

L Handle Frame adjustment

1. Standing on the left side of the machine, adjust the left handle to the right position, make your back against the back pad.
2. adjust the left hand to a usable position, began to exercise, after the brace is not restricted (no need to touch the R handle).

R Handle Frame adjustment

Back to the starting position, pull up the right handle, make sure the brace on limit shaft, Finished the exercise.

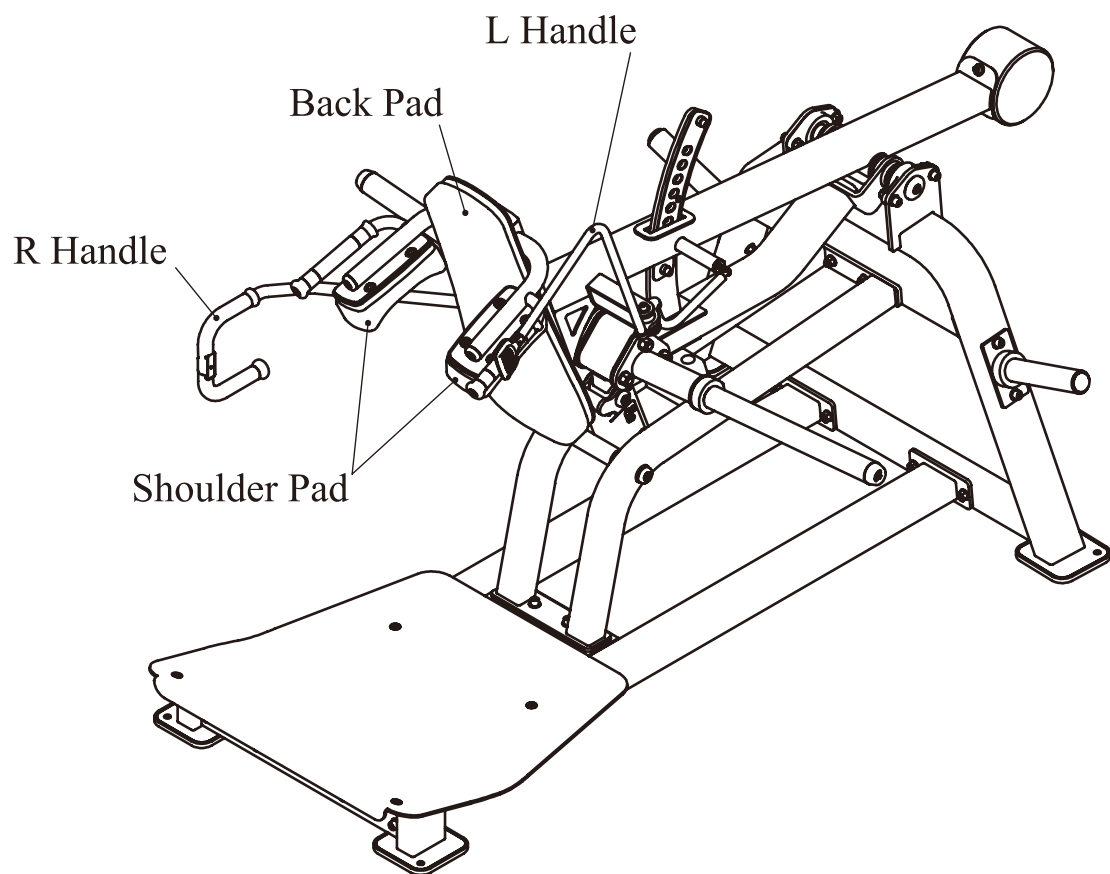

Maintenance Schedule

ROUTINE	COMMERCIAL MAINTENANCE	HOME MAINTENANCE	LATEST DATE ENTRY						
Inspect; Links, Pull Pins, Snap Locks, Swivels, Weight Stack Pins	DAILY	WEEKLY							
Clean; Upholstery	DAILY	WEEKLY							
Inspect; Cables or Belts and their tension	DAILY	WEEKLY							
Inspect; Accessory Bars, and Handles	WEEKLY	3 MONTHS							
Inspect; All Decals	WEEKLY	3 MONTHS							
Inspect; All Nuts and Bolts, Tighten if needed	WEEKLY	3 MONTHS							
Inspect; Anti-Skid Surface	WEEKLY	3 MONTHS							
Clean & Lubricate; Guide Rods with a Teflon (PTFE) based lubricant (Superlube)	MONTHLY	3 MONTHS							
Lubricate; Seat Sleeves, Turcite Bushings, Linear Bearing	MONTHLY	3 MONTHS							
Clean and Wax; All Glossy Finishes	6 MONTHS	YEARLY							
Repack with Grease; Linear Bearings	6 MONTHS	YEARLY							
Replace; Cables, Belts and Connecting Parts	YEARLY	3 YEARS							

Your equipment comes with a commercial maintenance decal. For personal, in home use, please follow the home maintenance schedule listed above.

General Maintenance Information

Links, Pull-Pins, Snap Hooks, Swivels, Weight Stack Pins:

- * Check all pieces for signs of visible wear or damage.
- * Check springs in snap hooks and pull-pins for proper tension and alignment.
- * If the spring sticks or has lost its rigidity, replace it immediately.

Upholstery:

- * To ensure prolonged upholstery life and proper hygiene, all upholstered pads should be wiped down with a damp cloth after every workout.
- * Periodically take the time to use a mild soap or an approved vinyl upholstery cleaner to deter the onset of cracking or drying. Avoid using any abrasive cleaners or cleaners not intended for use on vinyl.
- * Replace ripped or worn upholstery immediately.
- * Keep sharp or pointed objects clear of all upholstery.

Decals:

- * Inspect and familiarize yourself with any safety warnings or other user information posted on each decal.

Nuts and Bolts:

- * Inspect all nuts and bolts for any loosening and tighten if needed.
- * Go through a re-tightening sequence periodically to ensure that all hardware is tensioned proper.

Anti-Skid Surfaces:

- * These surfaces are designed to supply secure footing and need to be replaced if they appear worn or become slippery.

Belts and Cables:

- * We use only high quality belt, and mil-spec cables.
- * Visually inspect the belts and cables for fraying, cracking, peeling or discoloration.
- * While the machine is not in use, carefully run your fingers along the belt or cable to feel for thinning or bulging areas.
- * Replace belts and cables immediately at the first signs of damage or wear. Do not use equipment until belts or cables have been replaced.

Belt and Cable Tension:

- * Referring to the Owners Manual, when belts or cables are used check all bolts attachments to be sure they are properly attached.
- * Check slack in cables and re-adjust cable tension if needed.

Seat Sleeves, Guide Rods:

- * Wipe down adjusting tubes with a dust free rag before applying lubricant.
- * Lubricate seat sleeves and Guide Rods with a Silicon or Teflon based lubricant spray.

Linear Bearings:

- * Referring to the Owners Manual carefully disassemble the bearing from its housing and place a finger full of light grease (lithium, super lube, etc.) into the inside of the bearing. Using your finger, press the grease into the ball-bearings and their tracks. repeat until the ball-bearing tracks are full of grease. Insert the shaft back into the bearing and wipe off excess grease.

PLEASE KEEP THIS FOR YOUR RECORDS

Weight Training Tips

Use this manual to guide you through the basic exercises you can perform on your equipment. To gain maximum results and avoid possible injury, consult a fitness professional to develop your complete exercise program.

Always consult your physician before starting any exercise program.

To be successful in your exercise program, it is important to develop an understanding of the basic principles of strength training. Now that you have your equipment, it is only natural that you want to get started immediately. First, determine a set of realistic goals and objectives for yourself. By deciding on an exercise plan that is right for you prior to starting, you will contribute significantly to your success.

Warm up properly before engaging in weight resistance training. Stretching, yoga, jogging, calisthenics or other cardiovascular exercise can help prepare your body for the heavier workload of lifting weights.

Learn how to perform the exercise correctly before using heavy weight. Correct form is important to avoid injury and to ensure that you work the proper muscle groups.

Know your limitations. If you are new to weight training or are embarking on an exercise regimen after a long layoff, start slowly and build foundational strength over a longer period of time.

Pay attention to your breathing. Exhale when you exert is a general rule of thumb. Never hold your breath.

